

**ARMSTRONG**



Gold Series - Pump Less Volute Kit

FILE NO:	10.115
DATE:	Feb. 7, 2008
SUPERSEDES:	New
DATE:	Jan. 16, 2008

### ► Legacy of Reliability

Armstrong in-line circulators are favoured by system designers and chiller/boiler manufacturers who prefer 3-piece construction for reliability, efficiency, and serviceability. Owing to our history of product innovation and a mandate for design compatibility, today's models are direct substitutes for all compatible circulators built over the last 50 years.



### ► Upgrading Circulators By Others

Armstrong Gold Series - Pump Less Volute kits enable you to upgrade and renew circulators manufactured by others, to gain the benefits of Armstrong quality, service, and performance, along with these design innovations:

#### Universal SBA sealed bearing assemblies

- Significantly reduce spare parts requirements.

#### "One-size-fits-all" bearing module

- Allows repair of any model with only one module design.

#### Circular oil wick

- Provides superior lubrication for cooler running and longer life.

#### Viton mechanical seal

- Provides increase life expectancy for high temperature application.

#### Noryl non-ferrous impeller

- Designed for both hydronic and potable water applications.

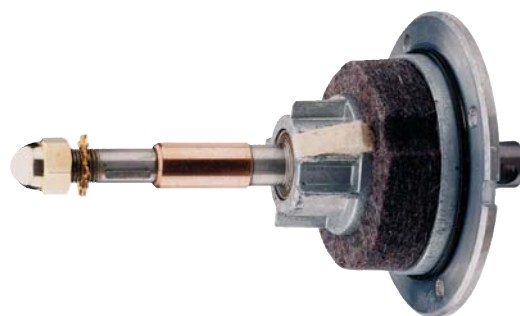

### ► Cross Reference Chart

PLV Kit	Motor		Circulator Manufacturer/Model		
	HP	Power	B&G	Taco Pro-Fit	ARMSTRONG
S-25 LV	1/12	115 Vac, single phase	100	RPK-A-100	S-25
H-32 LV	1/6		HV or 2"	RPK-B-101	H-32, S-35
H-41 LV	1/6		PR	RPK-C-100	H-41
S-45 LV	1/4		2½ or LD3	RPK-C-101	S-45 (2½ or 3")
S-46 LV	1/3		HD3	RPK-C-102	S-46
H-51 LV	1/4		60-11 (604S)	RPK-D-102	H-51, 1B
H-52 LV	1/3		60-2	RPK-D-103	H-52, 1¼B
H-53 LV	1/2		115/230 Vac, single phase or 208-230/460 Vac, three phase	60-13 (608S)	RPK-D-104/204
H-54 LV	3/4	PD37S, 60-14, 611T		RPK-D-101/201	H54, S-57, 2B
S-55 LV	1/2	PD35S		RPK-D-100/200	S-55

### ► Best Practice Solution - Saves Time and Money

Traditionally, service providers had to order a complete circulator. To save time and reduce the risk of pipe alignment problems and leak development by breaking and making pipe connections, some would remove and discard the brand new volute (casing), so the remaining "Pump - Less Volute" could be mated to the original casing.

With Armstrong Gold Series - Pump Less Volute kits, service contractors and building maintenance technicians can replace circulators faster, reduce cost, and avoid waste. You get a complete Armstrong circulator already "Less Volute", that is a direct substitute for the model to be replaced. Since the same moving parts are used for both cast iron and bronze circulators, only one kit model is required to service either type. This helps to further minimize spare parts inventory requirements for the building maintenance supervisor, and enables your Armstrong supplier to ensure the genuine replacement parts you need are readily available.

# Gold Series - Pump Less Volute Kit

## ► Raypak TIP Boiler Header Pumps

Throughout North America, the large installed base of original pumps may require frequent servicing as components wear out. Specific models of Armstrong Gold Series - Pump Less Volute kits are direct replacements for original pumps including pre-trimmed impellers for an exact performance match. Replacing all moving parts with one kit will provide years of service-free low-cost operation.

PLV Model	Base Circulator	Motor			Impeller Trim
		HP	Voltage	RPM	
Raypak 1	2B 1050 AB - LV	1/3	115 Vac, 1 phase	1750	4 3/8"
Raypak 2	2B 1050 AB - LV	1/2	115/208-230 Vac, 1 phase	1750	4 1/2"
Raypak 3	2B 1050 AB - LV	3/4	115/208-230 Vac, 1 phase	1750	4 1/2"
Raypak 4	2B 1050 AB - LV	1/2	115/208-230 Vac, 1 phase	1750	No impeller

## ► Design Information

Maximum Operating Temperature	225°F (107°C)
Maximum Working Pressure	125 psi (862 kPa)

## ► Materials of Construction

<b>Body</b>	Gold painted steel, radially split for servicing ease
<b>Motor</b>	Maintenance-free, permanently lubricated
<b>Sealed Bearing Assembly</b>	Armstrong SBA with universal bearing module <ul style="list-style-type: none"> <li>► Stainless steel face plate</li> <li>► Alloy steel shaft (heat treated for long life)</li> <li>► Copper sleeve</li> <li>► Circular oil wick</li> </ul>
<b>Coupler</b>	4-spring or Woods 3J flexible coupler
<b>Shaft</b>	Alloy steel (heat treated for long life), copper sleeve
<b>Mechanical Seal</b>	ARMseal™ carbon, ceramic seat, stainless steel trim, Viton seal
<b>Impeller</b>	Noryl (registered trade mark of GE Plastics)

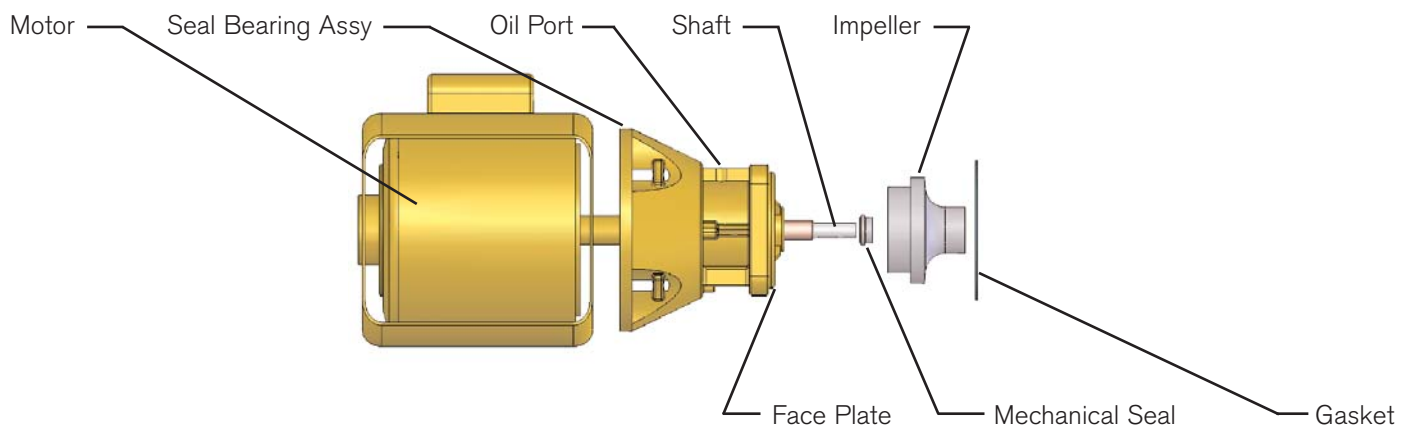

## ► Dimensions

PLV Kit	A	B	C	D	E	F	G
S-25 LV	6 1/8 (155)	2 3/4 (70)	12 5/8 (321)	3 7/8 (98)	1 1/4 (31)	1 1/4 (33)	3 3/8 (86)
H-32 LV	7 1/2 (190)	3 3/8 (86)	13 7/8 (354)	3 3/8 (84)	1 3/8 (36)	1 3/4 (44)	4 1/4 (107)
H-41 LV	7 1/2 (190)	4 1/4 (108)	14 1/8 (358)	3 3/8 (84)	1 1/4 (32)	1 3/4 (44)	5 3/8 (135)
S-45 LV	7 1/2 (190)	4 1/4 (108)	14 1/4 (360)	3 3/8 (84)	2 (50)	1 3/4 (45)	5 3/8 (135)
S-46 LV	7 1/2 (190)	4 1/4 (108)	14 1/4 (360)	3 3/8 (84)	2 (50)	1 3/4 (45)	5 3/8 (135)
H-51 LV	7 1/2 (190)	5 1/4 (135)	15 5/8 (396)	4 5/8 (117)	2 1/8 (53)	1 3/4 (43)	6 7/8 (173)
H-52 LV	7 1/2 (190)	5 1/4 (135)	15 5/8 (396)	4 5/8 (117)	2 1/8 (53)	1 3/4 (43)	6 7/8 (173)
H-53 LV	5 1/8 (130)	5 1/4 (135)	13 1/8 (333)	4 5/8 (117)	2 1/8 (53)	1 3/4 (43)	6 7/8 (173)
H-54 LV	10 3/8 (235)	5 1/4 (135)	17 3/4 (452)	4 5/8 (117)	2 1/8 (53)	2 1/8 (54)	6 7/8 (173)
S-55 LV	8 1/4 (210)	5 1/4 (135)	16 3/4 (426)	4 5/8 (117)	2 1/8 (53)	2 1/8 (54)	6 7/8 (173)
Raypak 1	7 1/2 (190)	4 3/8 (112)	14 3/4 (375)	4 5/8 (117)	2 1/8 (53)	2 1/8 (54)	6 7/8 (173)
Raypak 2	9 7/8 (251)	4 1/2 (115)	17 1/4 (439)	4 5/8 (117)	2 1/8 (53)	2 1/8 (54)	6 7/8 (173)
Raypak 3	10 3/8 (235)	4 1/2 (115)	17 3/4 (452)	4 5/8 (117)	2 1/8 (53)	2 1/8 (54)	6 7/8 (173)
Raypak 4	9 1/4 (235)	N/A	N/A	4 5/8 (117)	N/A	N/A	N/A

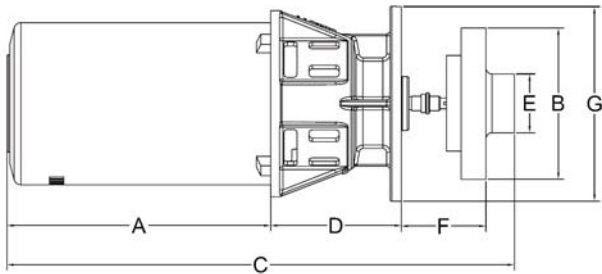

## ► Performance Chart

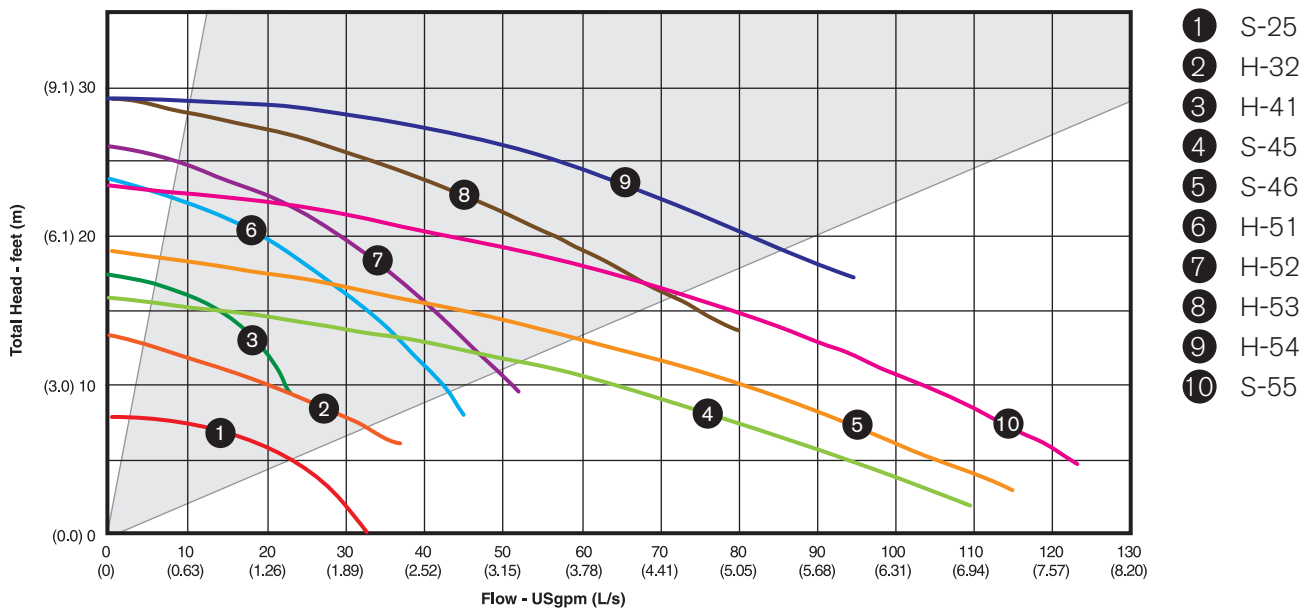

EXPERIENCE BUILDING...

**S. A. Armstrong Limited**  
 23 Bertrand Avenue  
 Toronto, Ontario  
 Canada, M1L 2P3  
 T: (416) 755-2291  
 F (Main): (416) 759-9101

**Armstrong Pumps Inc.**  
 93 East Avenue  
 North Tonawanda, New York  
 U.S.A., 14120-6594  
 T: (716) 693-8813  
 F: (716) 693-8970

**Armstrong Holden Brooke Pullen**  
 Wenlock Way  
 Manchester  
 United Kingdom, M12 5JL  
 T: +44 (0) 161 223 2223  
 F: +44 (0) 161 220 9660



© S.A. Armstrong Limited 2008

For Armstrong locations worldwide, please visit [www.armstrongpumps.com](http://www.armstrongpumps.com)